

Installation Instructions

MBC Battery Cabinet

BCA Battery Cabinet

Installation and wiring should be performed by qualified personnel only - Equipment damage and/or malfunction may result from improper installation. Remove all power from the system until the installation is complete and ready for testing. All work of any kind shall be performed to meet the requirements of any and all local, state and federal codes and/or standards set by the authority having jurisdiction. This enclosure is for Low Voltage use only. All conduit openings are available for low voltage use.

(2) 12 volt 60 Ah batteries Max. (< 40 VDC)

Installation Procedure

- Remove lift-away cover from back box and set aside (MBC Only)
- Place back box on wall where it is to be mounted and mark the location of holes to mount box to the wall.
- Drill appropriate size holes in wall for appropriate mounting screws being used, (screws not supplied).
- Mount back box to wall with appropriate hardware (not supplied).
- Replace cover onto unit. (MBC Only)
- Install ground strap w/(2) supplied screws. (MBC Only)

Equipment Supplied

- (1) Battery Cabinet
- (1) Ground strap kit (MBC Only)
- (1) Installation Instructions

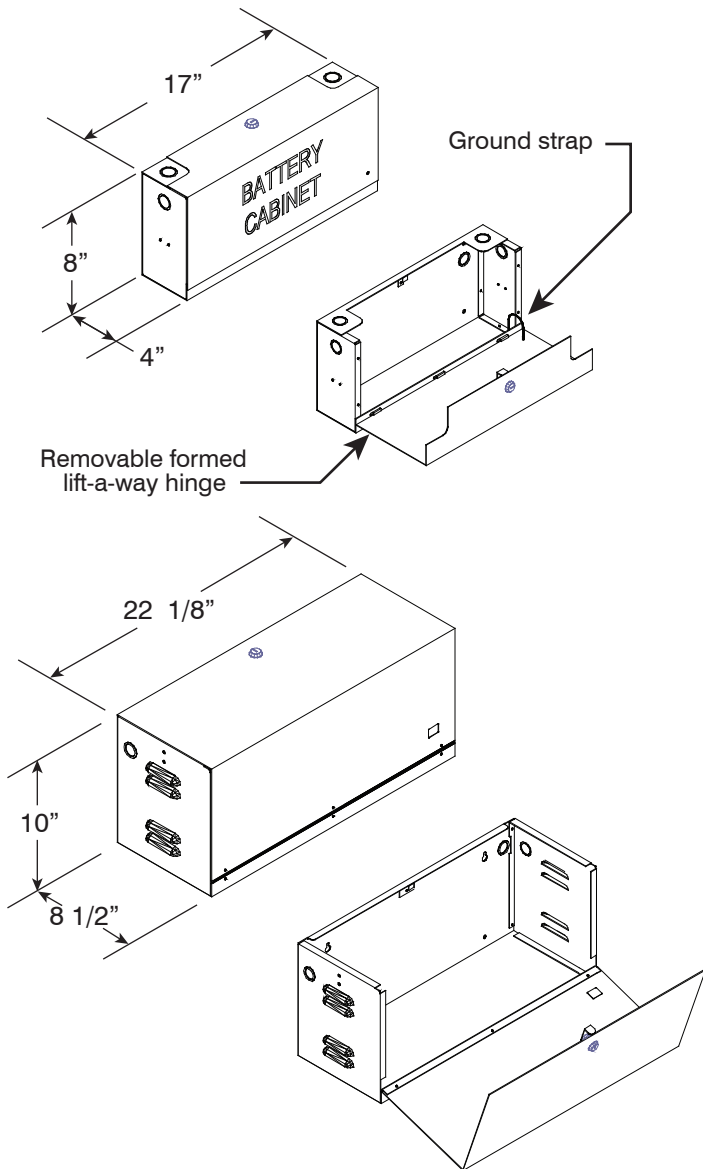

Ordering Information:

Part #	Description
SSU00500	BCA Battery Cabinet - Red
SSU00501	BCA Battery Cabinet - Black
SSU00505	MBC Mini Battery Cabinet - Red
SSU00506	MBC Mini Battery Cabinet - Black