



BY SPACE AGE ELECTRONICS

Weatherproof Duct Detector Enclosures



These weatherproof enclosures offer outdoor protection from rain, sleet and snow, or indoor protection from dripping water for SL-2000 and SM-501 duct smoke detectors.



Features

- Cold rolled steel construction (standard models), stainless steel construction (SE models)
- White painted finish
- Drip shield top
- Slip-on removable cover
- Embossed mounting holes on back of enclosure
- 3 knockouts in bottom of enclosure
- UL 50 type 3R / NEMA type 3R
- Foam gaskets for sampling/exhaust holes provided
- All hardware included
- SE models include vent tube kit to carry conditioned, indoor air flow into the enclosure to protect devices in Severe Environments



Ordering Information

P/N#	Description
SSU-WP-1	Weatherproof enclosure for SM-501 and EST SD-1
SSU-WP-1-SE	Weatherproof enclosure with vent tube kit for SM-501 and EST SD-1
SSU-WP-2000	Weatherproof enclosure for SL-2000
SSU-WP-2000-SE	Weatherproof enclosure with vent tube kit for SL-2000

Specifications

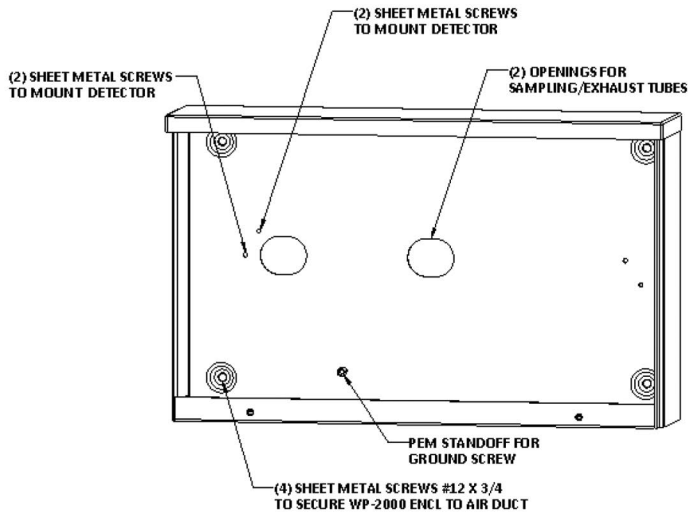

SSU-WP-2000

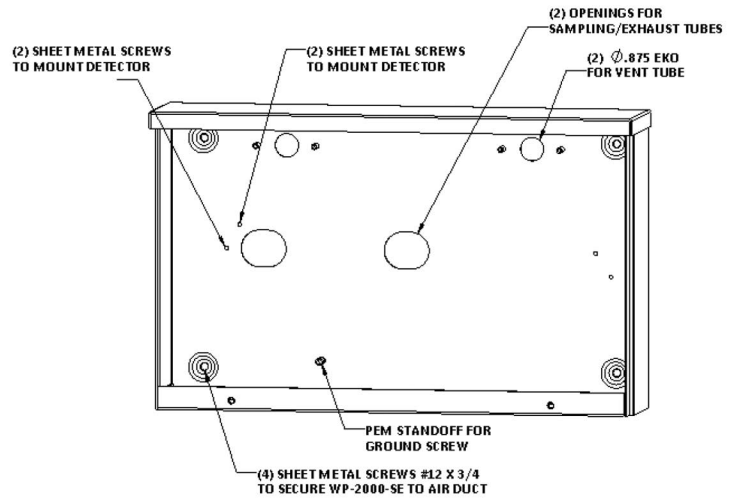

SSU-WP-2000-SE

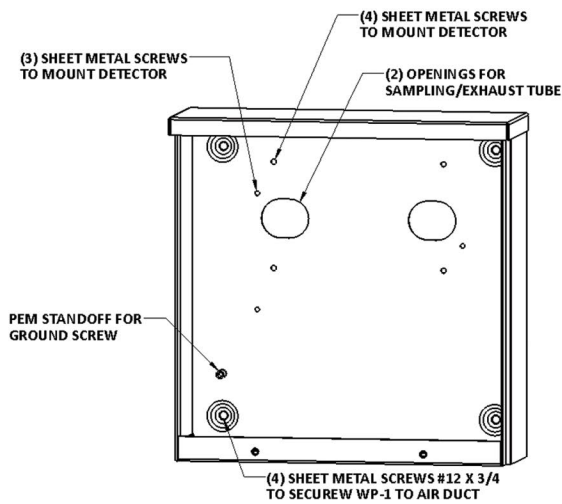

SSU-WP-1

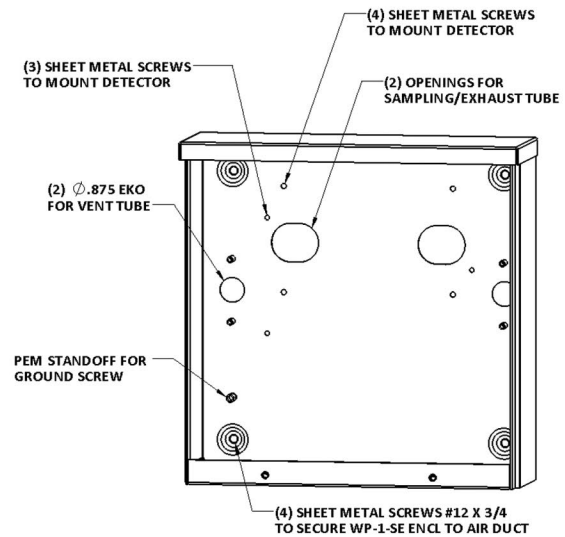

SSU-WP-1-SE

WPI/WPI-SE Dimensions

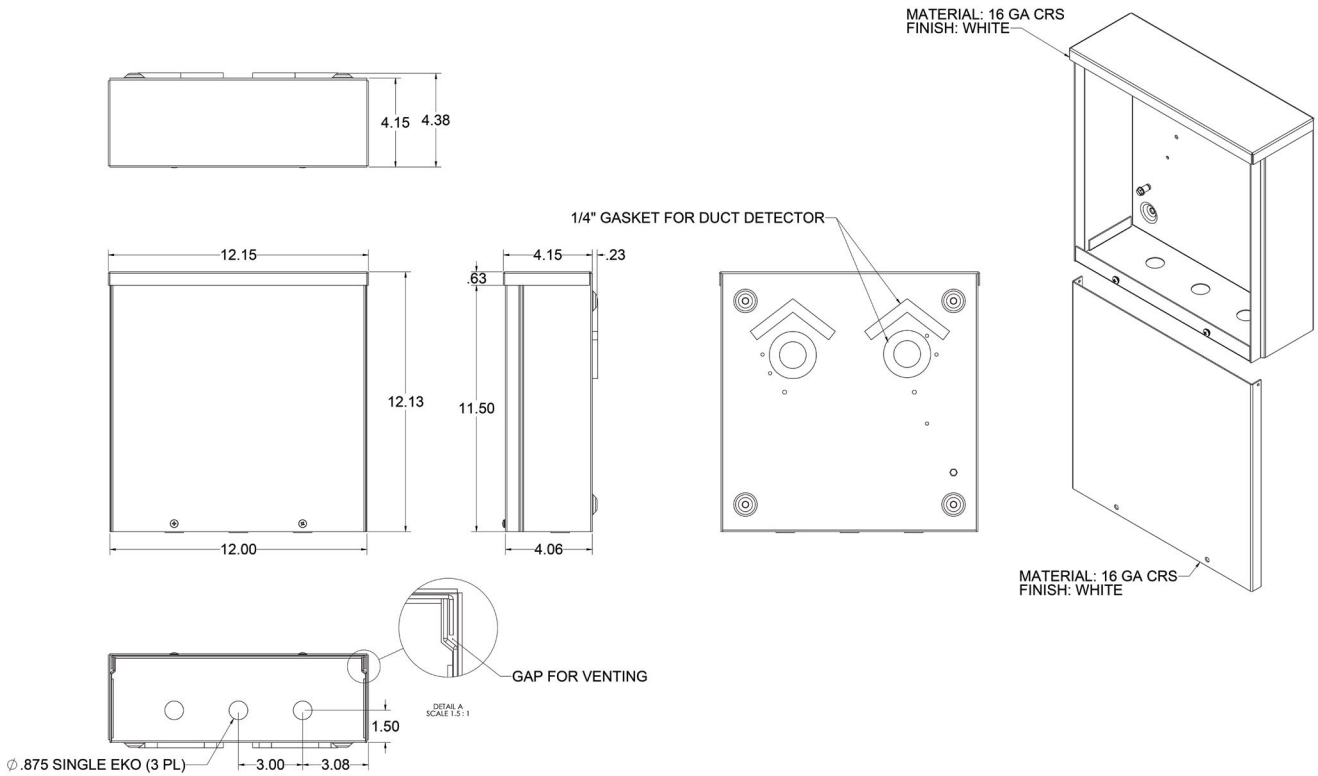

WP2000/WP2000-SE Dimensions

