

Installation Instructions

Multi Fast Rail 4/5 Module

4" with Edge Protector

Installation and wiring should be performed by qualified personnel only - Equipment damage and/or malfunction may result from improper installation. Remove all power from the system until the installation is complete and ready for testing. All work of any kind shall be performed to meet the requirements of any and all local, state and federal codes and/or standards set by the authority having jurisdiction.

Installation Procedure

- Install fastrail to device using supplied hardware.
- Install edge protectors by sliding them into each wire hole location and to end of part.
- To install (4) addressable modules. Line up hole pattern at one end of rail with module pattern. Use screws provided to mount module to fast rail. Place the next module to the one that was just installed.
- To install (5) addressable modules. There will be (3) modules will be mounted to the fast rail (both ends and in the center). The other (2) modules will be mounted on the modules using there screws to hold them in place. Line up hole pattern on rail with hole pattern on module. Use screws provided to mount module to fast rail.
- Connect all wiring to appropriate terminals.

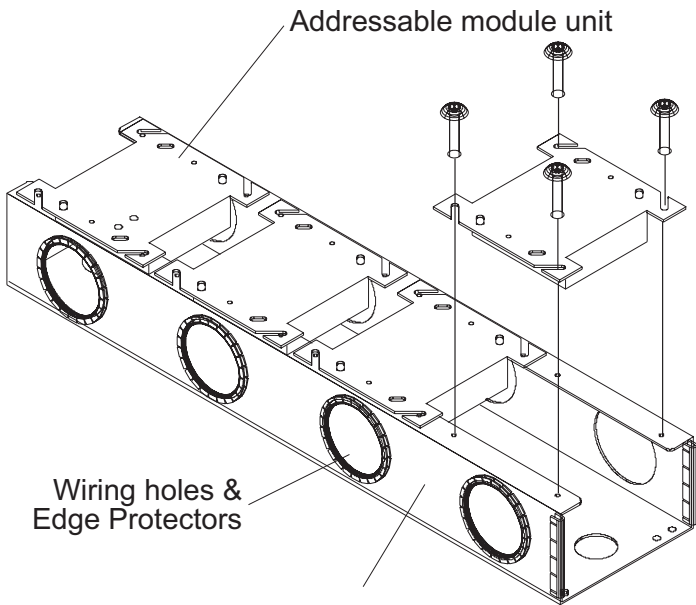

4 MODULES

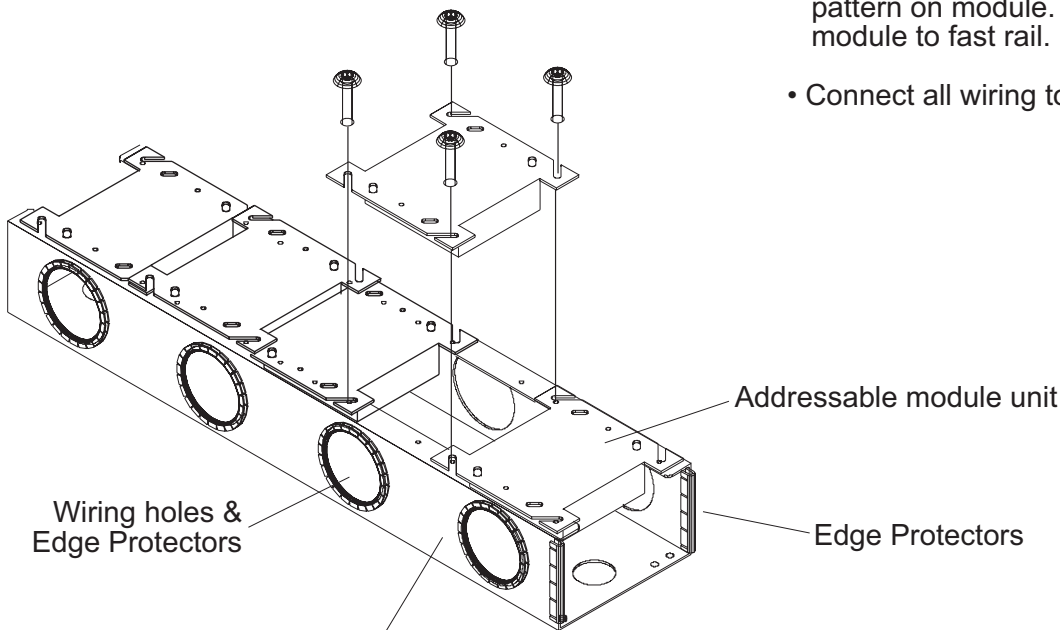

5 MODULES